



CONCRETE

INFORMATION

Intersection Joint Layout

Ideally, designers should develop an intersection joint layout while developing project plans. Though on paper, the plan view of an intersection provides the best birds-eye view for seeing the entire intersection. During construction it is difficult to visualize an intersection because of construction staging.

A good jointing plan will ease construction by providing clear guidance. It is common practice for some designers to leave intersection joint layout to the field engineer and contractor. These designers often justify this practice by citing the many field adjustments that occur during construction, which they contend negates the usefulness of a jointing plan. However, it is not desirable to eliminate the jointing plan except for very simple intersections. A jointing plan and appropriate field adjustments are both necessary for more complex intersections, because islands, medians and turning lanes complicate joint layout and require some forethought before construction. The plan will also enable contractors to more accurately bid the project.

During construction it is likely that location changes will be necessary for some joints within an intersection. The primary reason is to ensure that joints pass through fixtures embedded in the pavement like manholes or drainage inlets. It is common for the actual location of manholes, or drainage inlets to vary from the location shown on the plans. As a result, it will be desirable for the construction crew to adjust the location of some joints so that they coincide with the actual location of a nearby manhole or inlet. The designer should consider placing a note on the plan to give the field engineer and contractor the latitude to make appropriate adjustments.

The transverse and longitudinal joints in concrete pavement are necessary primarily to control cracking. The desirable transverse joint spacing depends on the slab thickness and subbase, but is usually about 4.5 m (15 ft). On typical roadway pavements, longitudinal joints divide lanes of traffic and in most cases are no more than about 4 m (12 ft) apart. Because the transverse and longitudinal joint spacing are usually not identical, it is difficult to maintain an even spacing on either roadway through an intersection.

The ten-step method in this publication provides intersection joint layout fundamentals. The examples show a right-angle and a skewed T-intersection. The detail diagrams show preferable alternates, but there may be

certain intersections with unique geometry that the methodology does not fully address. This publication does not address dowel and reinforcing requirements for joints.

A primary goal of this method is to minimize or eliminate joints that intersect another joint or the pavement edge at an acute angle. Experience shows that cracks often occur near acute angles, especially angles less than 60°. For most intersections it is possible to eliminate all angles less than 90° from the roadway slabs — there may be some acute angles in the curb and gutter. For skewed intersections it is likely that some joints will intersect at angles less than 90°. However, even for skewed intersections it is preferable to avoid angles less than 60°.

The method works equally well for integral curb and gutter, as well as for separate curb and gutter. The diagrams show how to place joints through curb and gutter and along curves between the intersecting roadways. The method also helps the designer produce a plan that is easier to construct by avoiding width changes along the edge of the mainline or primary paving lane(s).

New terms:

Doglegs: Construction block-outs at points where the pavement changes width. (See page 5 for details.)

Circumference-Return Line: A lightly drawn line 0.5-1.0 m (1.5-3.0 ft) from the face of the gutter along the curve between the edges of the intersecting roads. For obtuse angles, the line is 1/2 the nominal lane width from the gutter. Any joint that meets the circumference-return line is brought along the curve's radius to the back of the curb and gutter. Older publications use the term "off-set points" to refer to the points where joints return to the back of the curb.

Taper-Return Line: A lightly drawn line 0.5 m (1.5 ft) from the face of the gutter at the start of a turn lane taper. Any longitudinal joint that meets a taper-return line defines a location for a dogleg in the gutter.

Cross-Road Return Line: A lightly drawn line 0.5 m (1.5 ft) from the edge of a the mainline roadway at a skewed intersection. Any cross-road longitudinal joint will meet a transverse joint for the mainline roadway at the cross-road return line.

Intersection Box: The box formed by the edge of the mainline and intersecting paving lanes (including turning lanes).

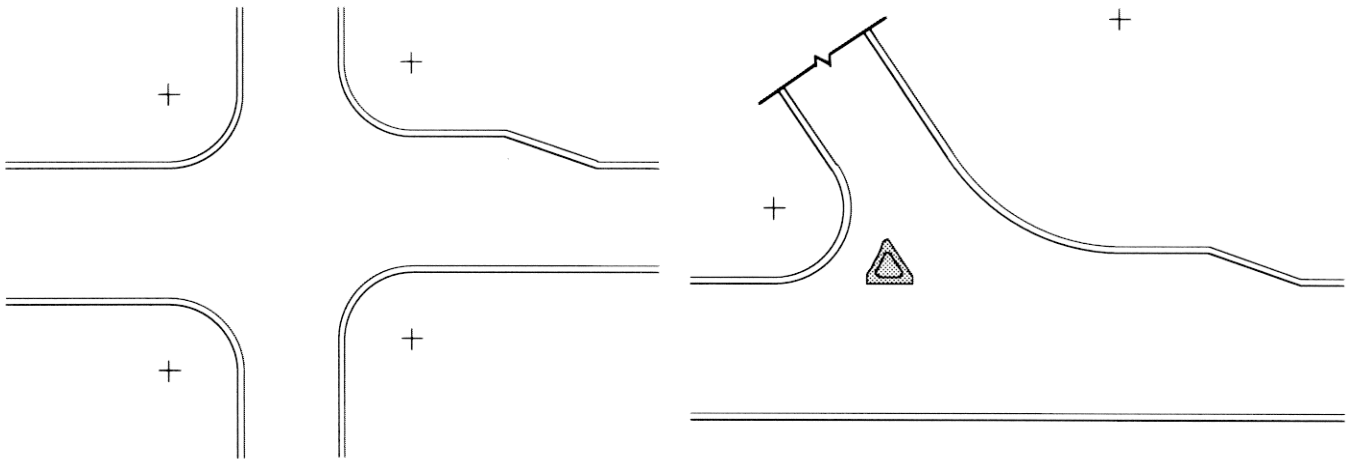

Step 1: Draw all pavement edge and back-of-curb lines on the plan view.

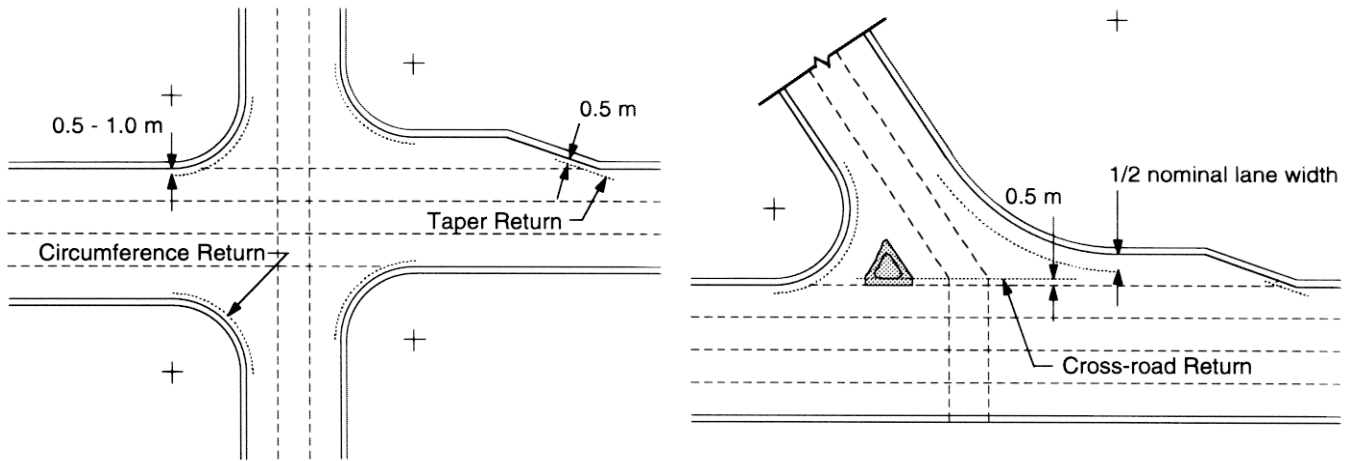

Step 2: Lightly draw the circumference-return, taper-return, and the cross-road-return line(s).

Step 3: Draw all lines that define lanes on the mainline and cross road. (Do not extend these lines past the circumference-return, taper-return or cross-road-return lines.)

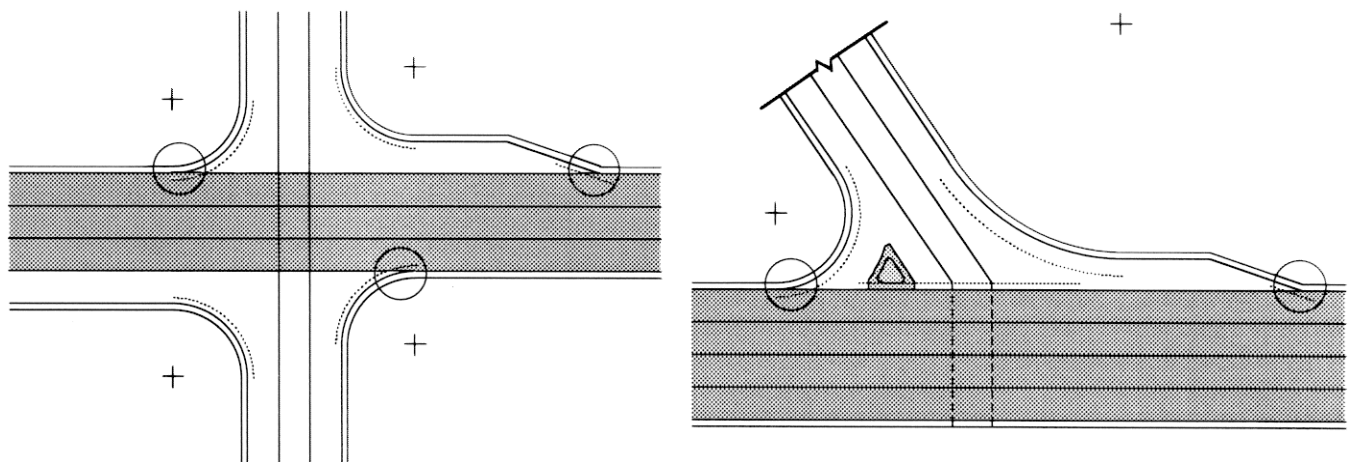

Step 4: Define the mainline lanes for paving. Find all locations where the mainline lanes intersect circumference-return or taper-return lines. At these locations only, extend the mainline paving edge lines past the circumference-return or taper-return line(s). Any block-outs for doglegs at these locations are preferable in the gutter for the curb.

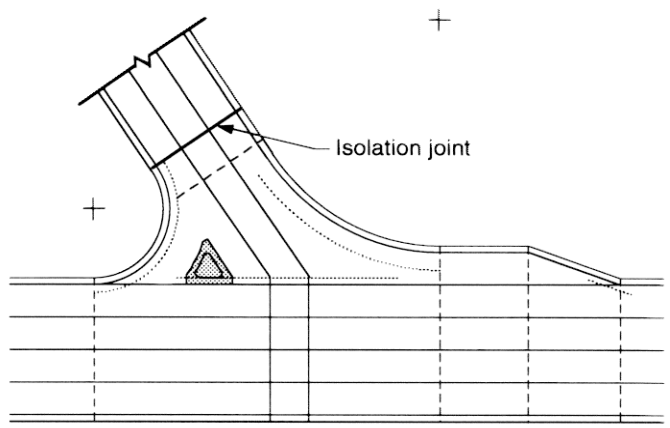
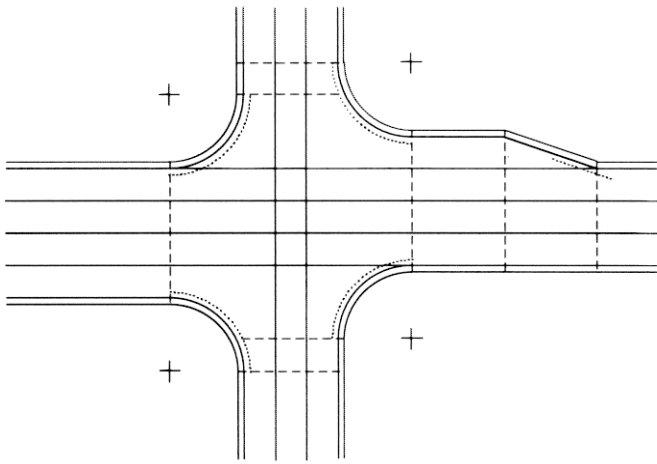

Step 5: Add transverse joints at all locations where the pavement changes width, extending the joints through the curb and gutter. Do not extend joints that intercept a circumference-return or cross-road-return line, except at the tangent points. The joint at the tangent point farthest from the mainline becomes an isolation joint in the cross road for T- and unsymmetrical intersections.

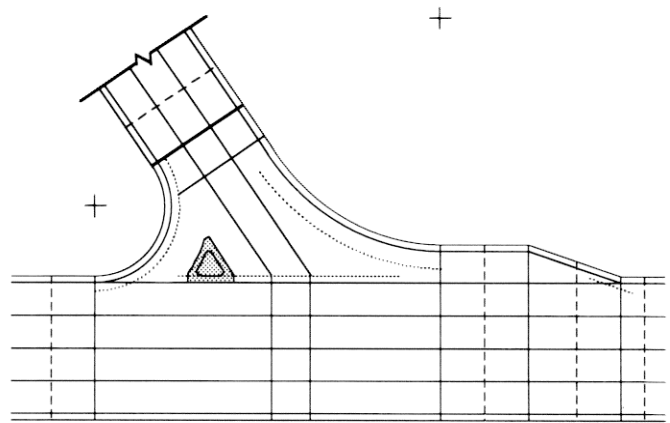
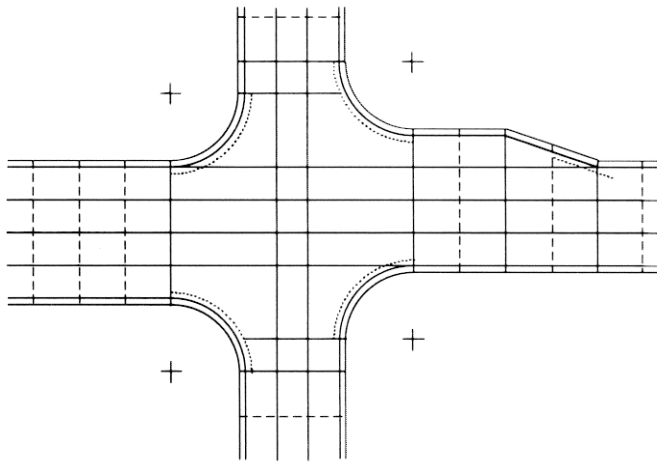

Step 6: Add transverse joint(s) between and beyond the joints you defined in Step 5, but do not add joints to the center of the intersection yet. Attempt to keep the distance between joints less than the maximum desirable length. Usually the maximum length is about 4.5 m (15 ft). (To calculate: $ML = Dx24$ for slabs on granular or unstabilized subbases; $ML = Dx21$ on stabilized subbases or existing asphalt or concrete pavements; ML =maximum length; D =slab thickness.)

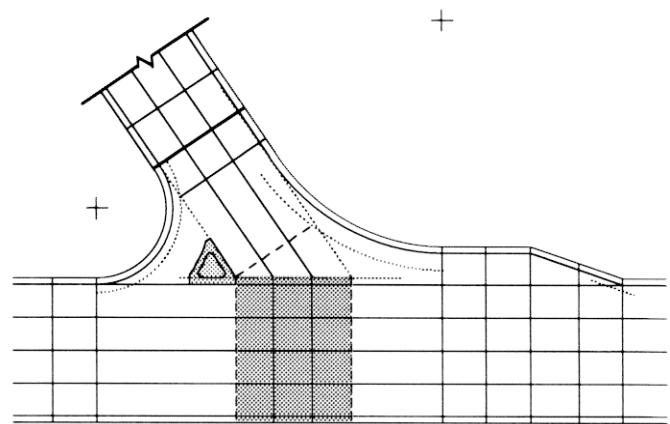
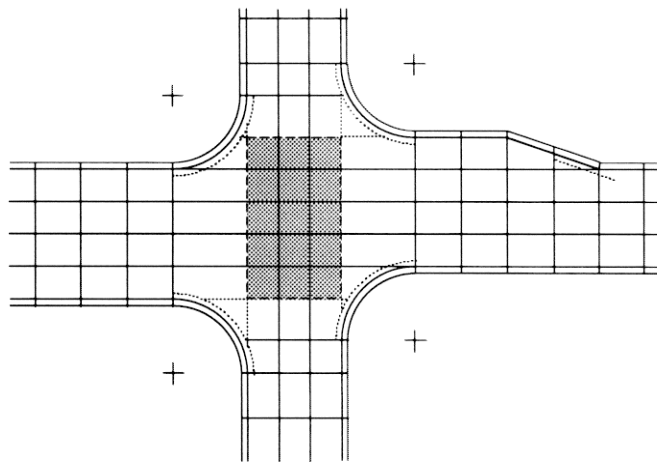

Step 7: By extending the edge of pavement lines for the cross road and any turning lanes, define the intersection box. (Note: For skewed intersections do not extend the lines for the turning lanes. Instead, place a transverse joint normal to the cross road centerline starting from the corner of the intersection box that is nearest to the acute angle of the intersection.)

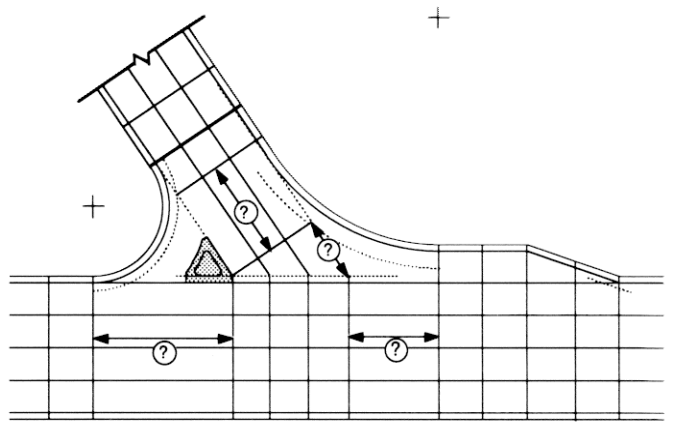
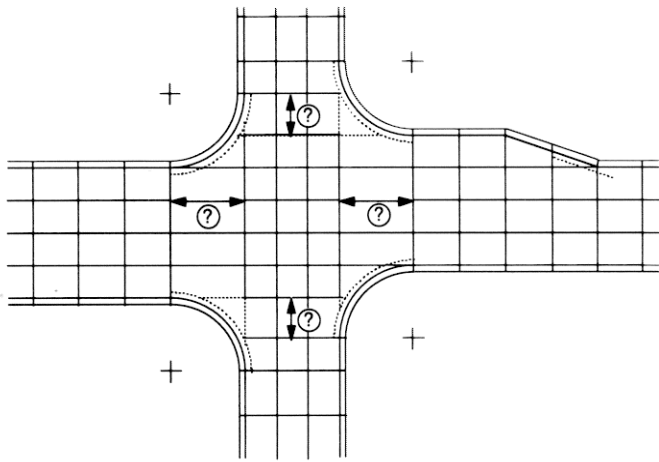

Step 8: Check the distances between the "intersection box" and the surrounding joints.

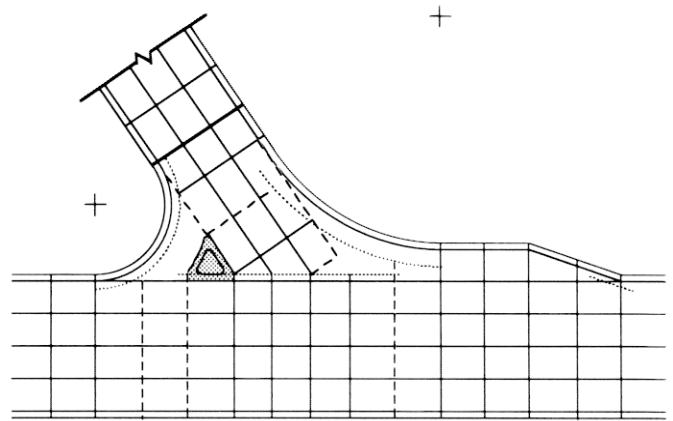
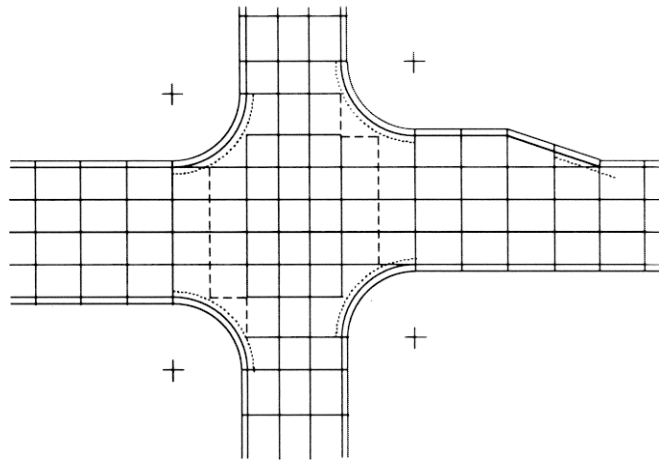

Step 9: If the distance is more than the maximum desirable joint spacing, then add transverse joint(s) at an equal spacing. Do not extend these joints past the circumference-return or cross-road-return lines.

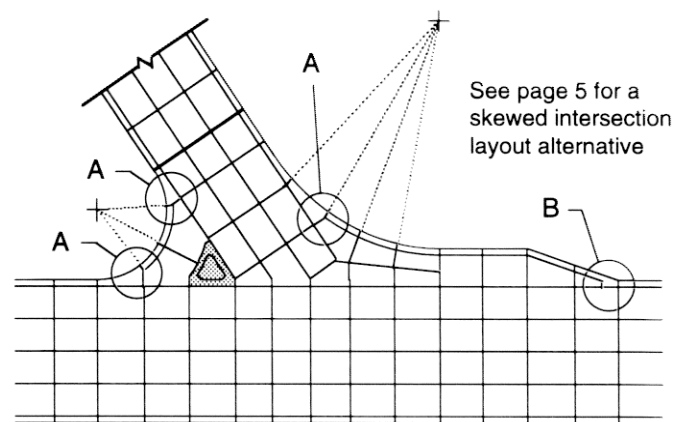
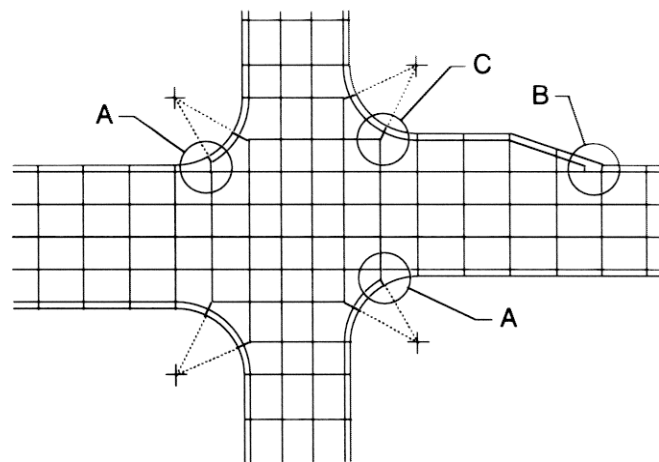

See page 5 for a skewed intersection layout alternative

Step 10: Lightly extend lines from the center of the curve(s) to the points defined by the "intersection box," any intermediate joints surrounding the "intersection box" and point(s) along any islands. Add joints along these radius lines. Finally, make slight adjustments to eliminate doglegs in mainline edges. (See details on page 5.)

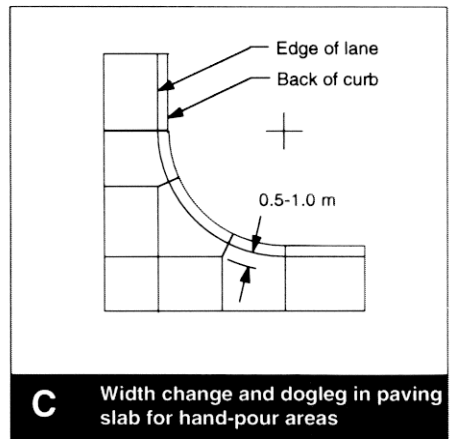
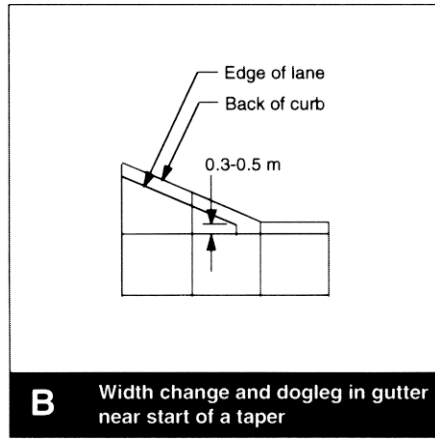
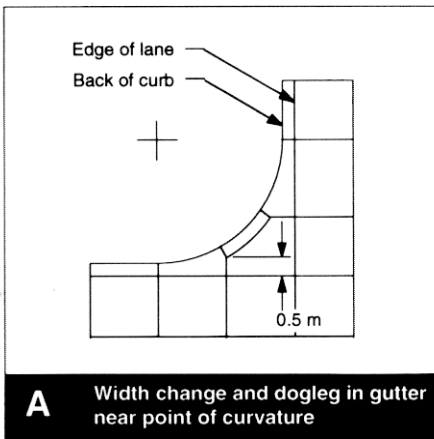

Skewed Intersection Layout Alternative

This alternative for a skewed intersection is useful for simple curve radii greater than 11 m (36 ft) and offset or compound radius curves. It can simplify field construction when the contractor builds the curve area in a single hand pour (indicated by the shaded area).

It is necessary to add an additional longitudinal joint near the center of the slabs that exceed 5 m (15 ft) wide. The additional joint should prevent the occurrence of a longitudinal crack. It is desirable to begin and end the additional longitudinal joint at a transverse joint, as shown in the diagram. Some agencies core a small 50-mm (2-in.) hole through the slab at the ends of this longitudinal joint to prevent sympathy cracking (see diagram).

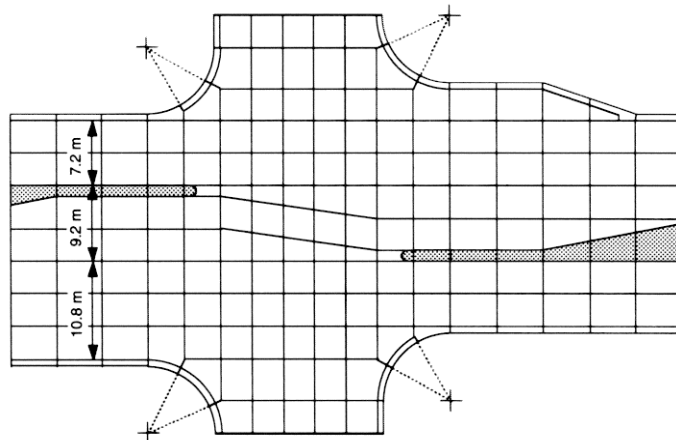
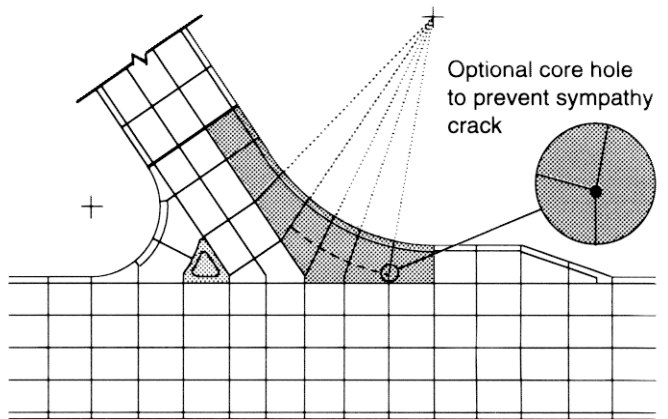

Handling Wide Medians and Dual-Left Turn Lanes

Large urban and suburban intersections that contain dual-left turn lanes, create joint alignment challenges. The medians in these large intersections are often up to 9.2 m (30 ft) wide. The diagram shows how to skew joints through the intersection box in order to maintain the joints along the lane lines for dual-left turn lanes. The ability to use this method will depend on construction staging; it is just one option to apply for complex intersections.

Adjusting Joints for Utility Fixtures

After developing the jointing plan, plot any catch basins, manholes or other fixtures that are within the intersection. Non-telescoping manholes will require a boxout or isolation to allow for vertical and horizontal slab movement. Consider using rounded boxouts or placing fillets on the corners of square boxouts to avoid crack-inducing corners. Also for square boxouts, wire-mesh or small-diameter reinforcing bars in the concrete around any interior corners will hold cracks tight should they develop. Telescoping manholes can be cast integrally within the concrete, and do not necessarily require a boxout. The two-piece casting does not inhibit vertical movement and is less likely to create cracks within the pavement.

Finally, when a joint is within 1.5 m (5 ft) of a fixture, it is desirable to adjust the joint so that it will pass through the fixture or the boxout surrounding the fixture. The diagram on the right shows several acceptable ways to skew or shift a joint to meet a fixture.

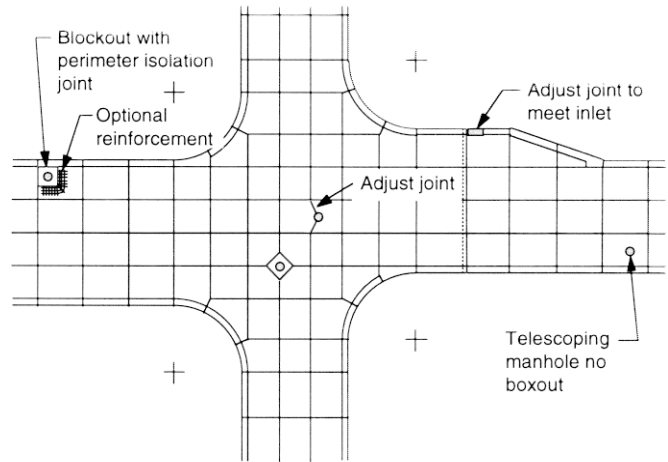

Details for Boxing Out Fixtures

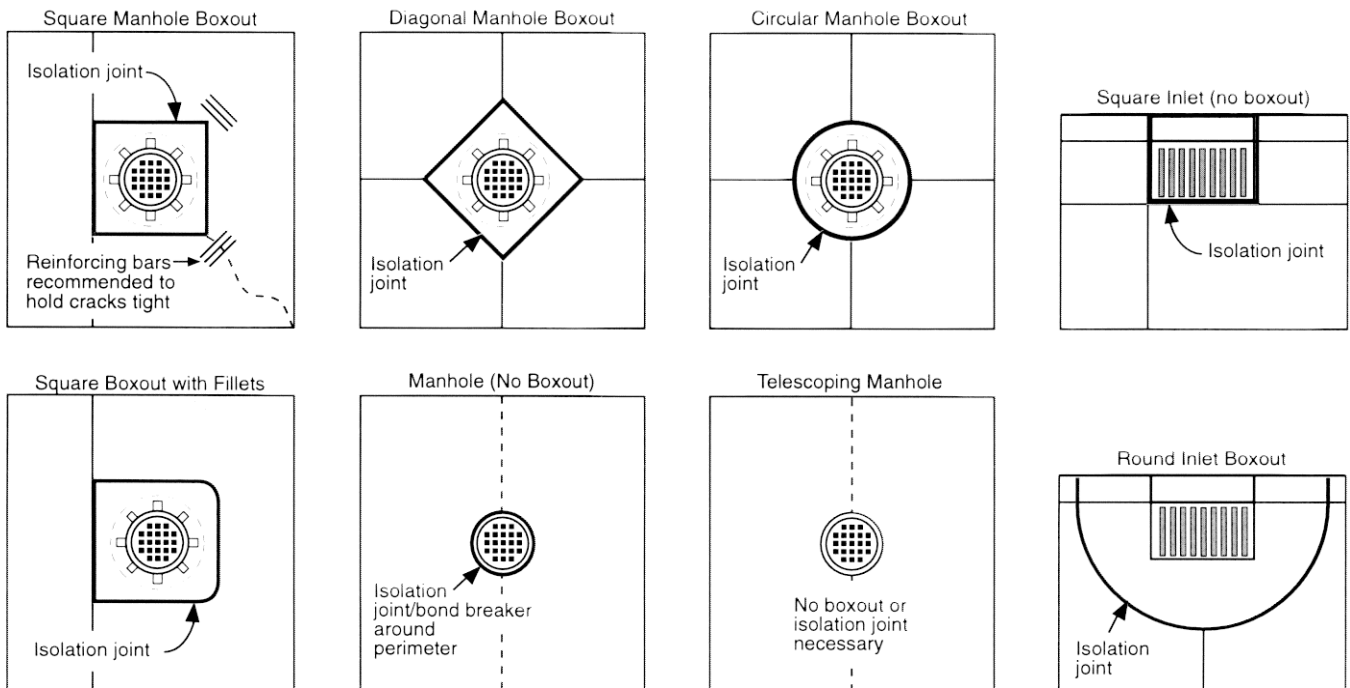

- Notes:
1. Isolation joints should be at least 12 mm (1/2 in.) wide and filled with a compressible material.
 2. Boxouts should be large enough to provide at least 0.3 m (1 ft) clearance between the fixture and the surrounding isolation joint.

This publication is intended SOLELY for use by PROFESSIONAL PERSONNEL who are competent to evaluate the significance and limitations of the information provided herein, and who will accept total responsibility for the application of this information. The American Concrete Pavement Association DISCLAIMS any and all RESPONSIBILITY and LIABILITY for the accuracy of and the application of the information contained in this publication to the full extent permitted by law.



American Concrete Pavement Association
5420 Old Orchard Road, Suite A100
Skokie, IL 60077-1059